

LUBRICATE ALL SEALS WITH CLEAN HYDRAULIC OIL PRIOR TO ASSEMBLY. DO NOT USE SILICONE BASED LUBRICANTS.

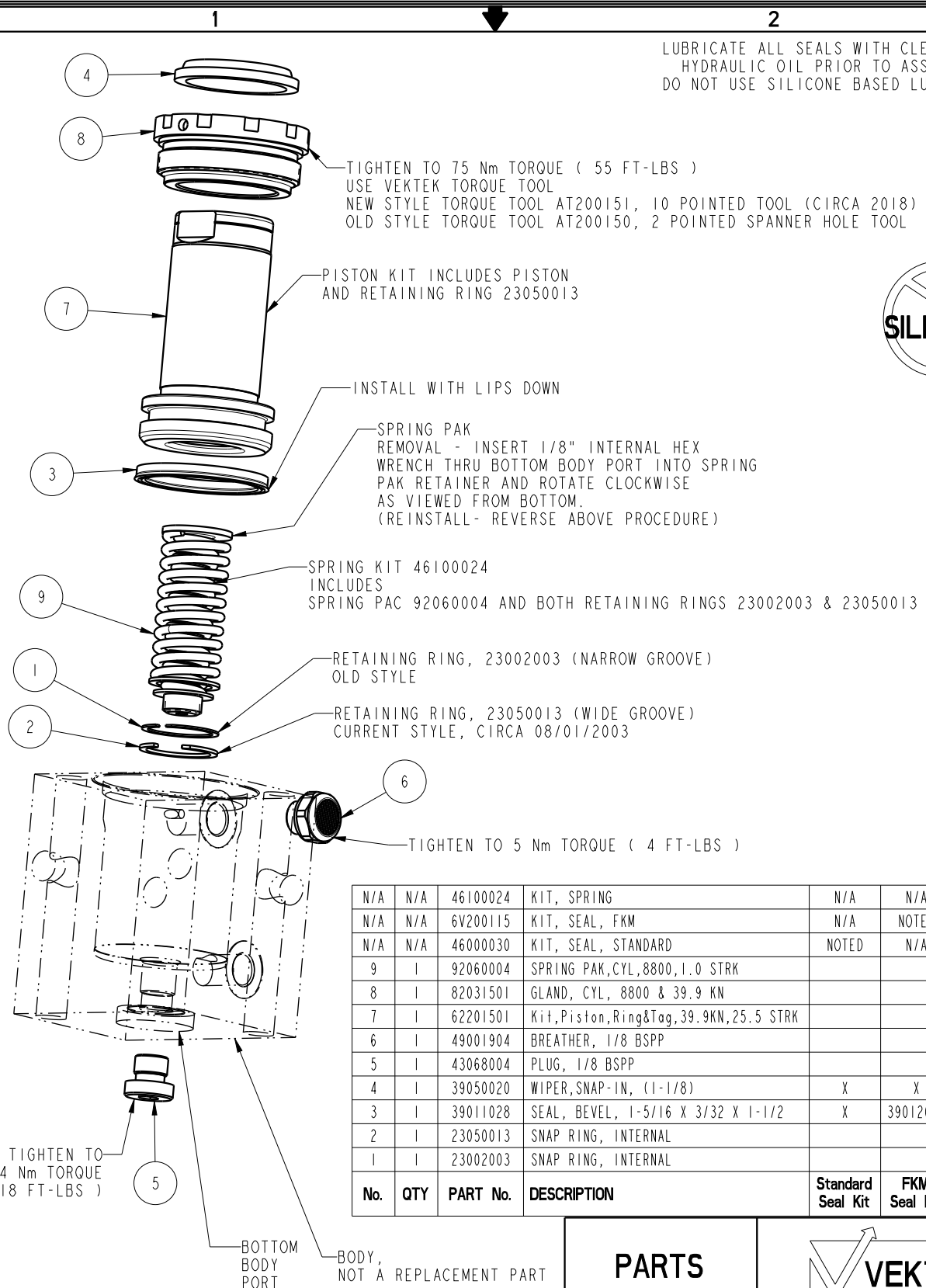

TIGHTEN TO 75 Nm TORQUE (55 FT-LBS)
 USE VEKTEK TORQUE TOOL
 NEW STYLE TORQUE TOOL AT200151, 10 POINTED TOOL (CIRCA 2018)
 OLD STYLE TORQUE TOOL AT200150, 2 POINTED SPANNER HOLE TOOL

PISTON KIT INCLUDES PISTON AND RETAINING RING 23050013

INSTALL WITH LIPS DOWN

SPRING PAK REMOVAL - INSERT 1/8" INTERNAL HEX WRENCH THRU BOTTOM BODY PORT INTO SPRING PAK RETAINER AND ROTATE CLOCKWISE AS VIEWED FROM BOTTOM. (REINSTALL - REVERSE ABOVE PROCEDURE)

SPRING KIT 46100024 INCLUDES SPRING PAC 92060004 AND BOTH RETAINING RINGS 23002003 & 23050013

RETAINING RING, 23002003 (NARROW GROOVE) OLD STYLE

RETAINING RING, 23050013 (WIDE GROOVE) CURRENT STYLE, CIRCA 08/01/2003

TIGHTEN TO 5 Nm TORQUE (4 FT-LBS)

TIGHTEN TO 24 Nm TORQUE (18 FT-LBS)

BOTTOM BODY PORT
 BODY, NOT A REPLACEMENT PART

No.	QTY	PART No.	DESCRIPTION	Standard Seal Kit	FKM Seal Kit	Spring Kit
N/A	N/A	46100024	KIT, SPRING	N/A	N/A	NOTED
N/A	N/A	6V200115	KIT, SEAL, FKM	N/A	NOTED	N/A
N/A	N/A	46000030	KIT, SEAL, STANDARD	NOTED	N/A	N/A
9	1	92060004	SPRING PAK, CYL, 8800, 1.0 STRK			X
8	1	82031501	GLAND, CYL, 8800 & 39.9 KN			
7	1	62201501	Kit, Piston, Ring & Tag, 39.9KN, 25.5 STRK			
6	1	49001904	BREATHER, 1/8 BSPP			
5	1	43068004	PLUG, 1/8 BSPP			
4	1	39050020	WIPER, SNAP-IN, (1-1/8)	X	X	
3	1	39011028	SEAL, BEVEL, 1-5/16 X 3/32 X 1-1/2	X	39012015	
2	1	23050013	SNAP RING, INTERNAL			X
1	1	23002003	SNAP RING, INTERNAL			X

PARTS LIST



VEKTEK, INC.
 1334 E. SIXTH AVE. P.O. BOX 625
 EMPORIA, KS. 66801 U.S.A.

ASSEMBLIES AFFECTED
 42011006

PARTS LIST, ASSY, CYL, BB, 39, 9KN, 25, 5 STRK, SA

J	4249	RELEASE	JDW	08/13/20
REV	IN ACCORDANCE WITH ECN	EFFECTIVE DATE	REVISED BY	DATE
DRW BY:	BUSH	DRAWING STATUS: Released		
DATE:	12/15/94	PRODUCTION APPROVED FOR RELEASED STATUS ONLY		

SIZE A
MPL2062
 REV J